

## CHILLERS

Timothy C Wray P.E. July 1999

### A. TYPES OF ELECTRIC DRIVEN CHILLERS

1.     20 to 60 tons                     Hermetic reciprocating or scroll  
        40 to 150 tons                 Reciprocating  
        100 to 1,200+ tons             Screw open and hermetic  
        100 to 1,500 tons             Centrifugal  
        1500 to 3,000+ tons           Customs Centrifugal  
        ½ to 250 tons                 Air Cooled - Scroll, Recip, Screw
  
2.     Screw Compressors
  - a.     Oil seal
  - b.     Good turn down
  - c.     + 0.60 KW/Ton
  - d.     Noisy, both motor and compressor
  
3.     2 & 3 stage centrifugal - (Trane low pressure chillers)
  - a.     High efficiency
  - b.     Good turn down
  - c.     + 0.50 KW/Ton
  - d.     Quite
  
4.     Gear Drive Centrifugal
  - a.     Good efficiency
  - b.     25% turn down
  - c.     + 0.600 KW/Ton
  - d.     Noisy
  - e.     Requires some additional maintenance
  
5.     Air Cooled
  - a.     Reciprocating / Scrolls - 20 to 150 tons
  - b.     Screws - 60 to 250 tons
  - c.     Centrifugal - 150 to 300 tons
  - d.     1.2 to 2.0 KW/TON
  - e.     Easy maintenance
    - (1)    No cooling towers or water chemical maintenance
    - (2)    No condenser water pumps

**B. ALTERNATE DRIVE SOURCES FOR CENTRIFUGAL MACHINES**

1. Engine driven - open drive.
  - a. Great efficient, +Absorption chiller for waste heat
  - b. Large footprint
  - c. Requires extra maintenance, Run time tear down
  - d. Expensive
  - e. Noisy and should be in separated room.
2. Steam Turbine - open drive.
  - a. Need high pressure steam for economics
  - b. Need to be above 800 tons for economics
  - c. Better turn down, faster start up colder water than Absorber.
  - d. Large foot print.
  - e. Cooling towers should be sized to handle the additional load of condensing the steam.

**C. ABSORPTION**

1. Steam
  - a. Two stage, high pressure @ 10#/ton
  - b. Single stage, low pressure @ 17#/ton
2. Hot water
  - a. 250° and up hot water
  - b. + 18,000 btu/ton
3. Gas fired
  - a. Efficient, Low KW/Ton
  - b. Can heat or cool, but not at same time
  - c. Requires extra maintenance
  - d. Expensive

**D. WATER**

1. Condenser Water (Cooling tower)
  - a. 10°Δ to 12° Δ temperatures for electric chillers.
  - b. 15°Δ to 17°Δ temperatures for Absorption chillers.
  - c. Typical temperatures 95°-85° or 105° 0-85°
  - d. Start up - 75° min temperature on most machines.
  - e. Absorption should never fall below 70 degrees even under full load on most machines.

2. Chilled Water -
  - a.  $10^{\circ}\Delta$ , Typically  $45^{\circ}$  to  $55^{\circ}$
  - b.  $12^{\circ}\Delta$  &  $15^{\circ}\Delta$  chiller will operate more efficiently
    - (1) Saves pump HP / Chilled water coils are larger.
  - c. Lower water temperatures ,
  - d. Absorption -  $42^{\circ}$  min. water temp.
3. Pressure Drops
  - a. Number of passes - single pass or multiple passes
  - b. Enhanced Tube - turbulence
  - c. Condenser (Cooling Tower) - 15' (Try for less)
  - d. Evaporator (Chilled Water) - 20' (Try for less)
  - e. Tube velocity, typically 7 FPS
4. Connection type
  - a. Victaulic
  - b. Flanged
  - c. Marine box

#### E. REFRIGERANTS

1. Phased out
  - a. R-11 - Old low pressure Typically all old Trane Centrifugal
  - b. R-12 - Old medium pressure
2. New replacement Refrigerants
  - a. R123 replaces R-11
  - b. R134A replaces R-12
3. R-22 on the way out (2015? stop production)

#### F. SAFETY REQUIREMENT

1. Rupture disk - Typically low pressure machines
2. Safety Relief Valving
3. Refrigerant Monitor
4. Exhaust fans

#### G. START-UP AND JOBSITE OBSERVATION.

1. Verify refrigerant monitor is operational.
2. Verify Safety relief piped outside.
3. Verify pumps rotation and pressures.
4. Verify flow switch or differential pressure switch installation.
5. Verify water temperatures at thermometers and Pete's plugs Vs Chiller control panel.
6. Stand back and let the Manufactures Start-up person do there job.

# HERMETIC SCROLL

Large discharge gas volume for lower pressure pulsation.

Improved check valve — for quiet shutdown and less flow restriction.

Reverse vent preventing scroll damage during reverse rotation caused by improper phase connection.

High strength cast iron fixed and orbiting scroll resulting in less thermal distortion, less leakage and higher efficiency, EER.

Optimized involute geometry for higher efficiency, EER

Fixed throw prevents scroll impact and resulting noise.

Journal bearings for lower sound.

Motor tube for more accurate lower bearing alignment. Also, permits suction gas to enter shell prior to flowing through and cooling the motor. Dirt particles will then drop out and settle in the sump.

Internal motor temperature sensor is part of field proven protection system.

High efficiency motor for lower energy consumption.

High volume oil sump maintains lubrication during periods of high oil carryover.

Oil charging valve for changing or adjusting oil level.

Dirt separator for maximum bearing life.

Sight glass to monitor oil level.

- EER's range to 11.5
- Proven design

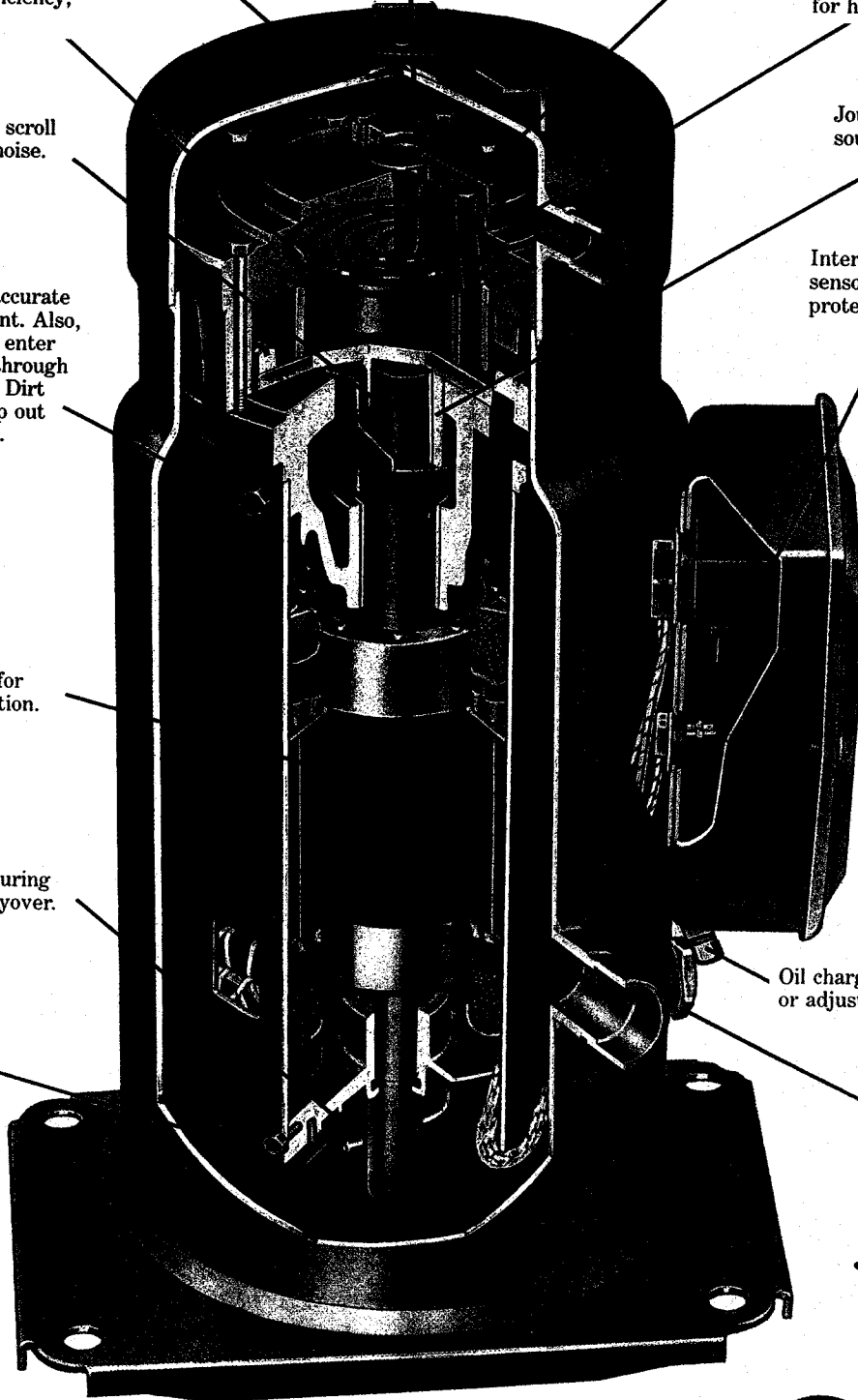

# Features and Benefits

## Trane Scroll Compressor

— Maximum Efficiency with Enhanced Reliability

### General

The scroll compressor has two scrolls. The top scroll is fixed and the bottom scroll orbits. Each scroll has walls in a spiral shape that intermesh.

### Inlet-First Orbit

As the bottom scroll orbits, two refrigerant gas pockets are formed and enclosed.

### Compression-Second Orbit

The refrigerant gas is compressed as the volume is reduced closer to the center of the scroll.

### Discharge-Third Orbit

The gas is compressed further and discharged through a small port in the center of the fixed scroll.

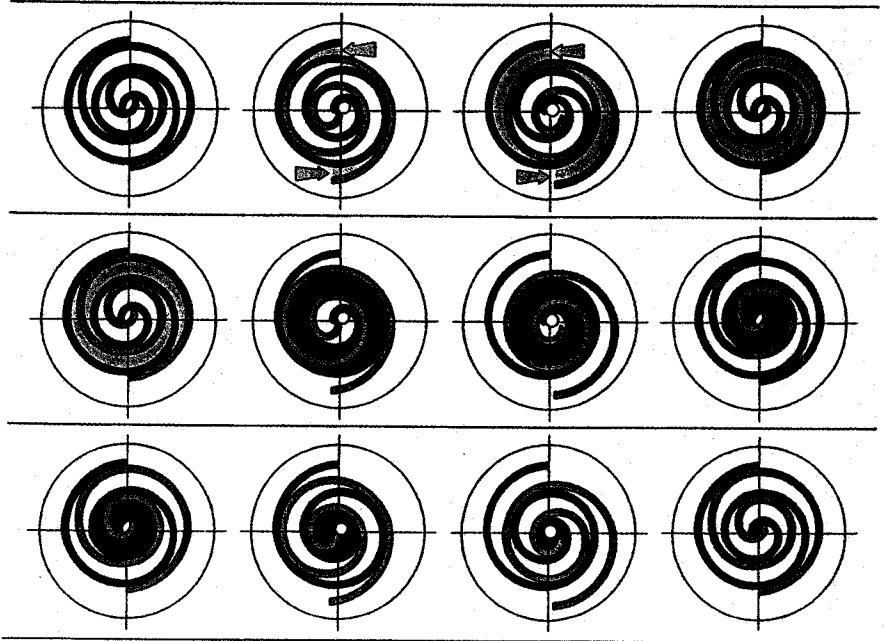

### Scroll Principal Components

This is a cutaway view of a hermetic, scroll compressor, showing the relative positions of the principal components. Shown is a Trane 10-ton, 3600 rpm, scroll compressor as an example.

The principle of operation of this example compressor is as follows: The suction gas is drawn into the compressor at A. The gas then passes through the gap between the rotor and stator, B, cooling the motor, before it enters the compressor housing, C. Here, the velocity of the gas is reduced, causing a separation of the entrained oil from the gas stream. The gas then enters the intake chamber, D, that encircles the scrolls.

Finally, the suction gas is drawn into the scroll assembly where it is compressed and discharged into the dome of the compressor. The dome of this example compressor acts as a hot gas muffler which dampens the pulsations before the gas enters the discharge line, E.

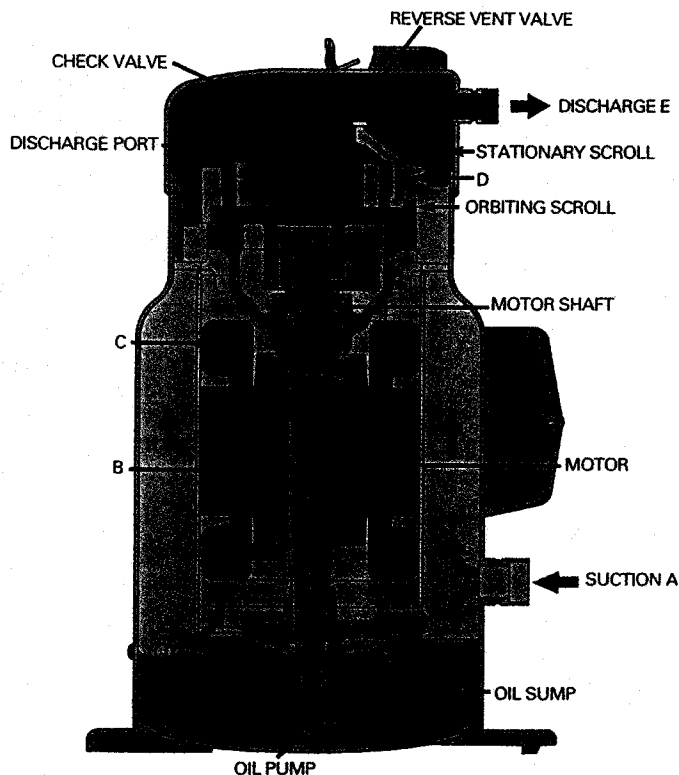

# HERMETIC SCROLL CHILLER

Power Supply Monitor Protects Compressors From Phase Loss, Phase Reversal, Phase Imbalance, Incorrect Phase Sequence and Under and Over Voltage

Control Panel

Microprocessor Operator Interface

Condenser Leaving Water Piping

Condenser Entering Water Piping

Rugged Trane Scroll Compressor

Evaporator Leaving Water Piping

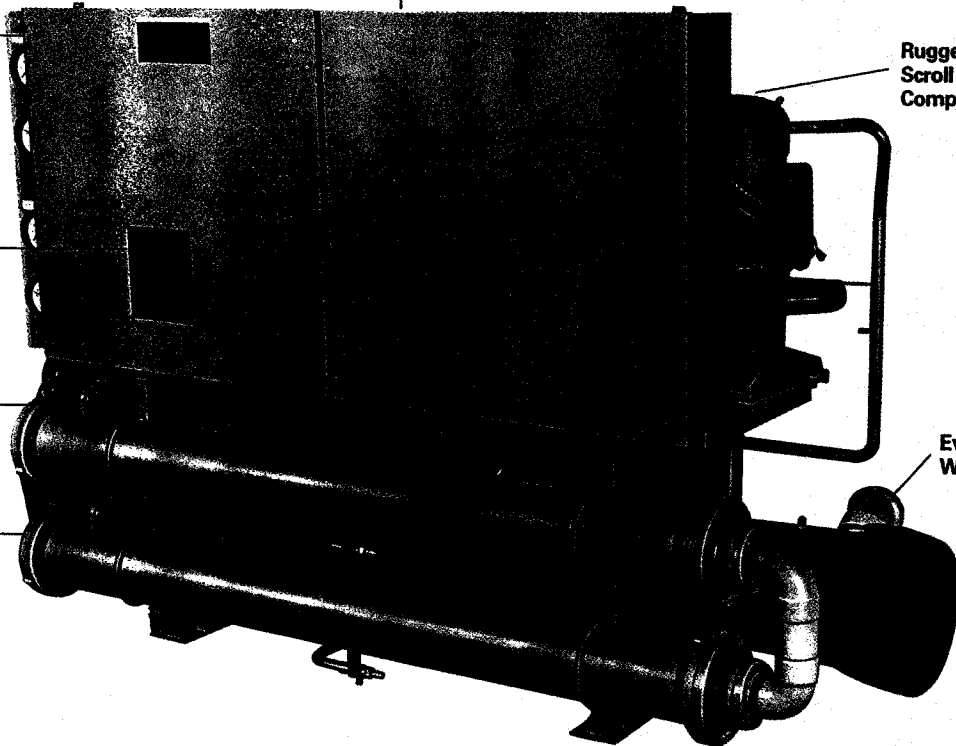

**RecipPak™**  
**LIQUID CHILLERS**  
**WATER COOLED & REMOTE CONDENSER**  
**MODELS**

R-22

60 TO 250 TONS  
(50 & 60 HZ.)

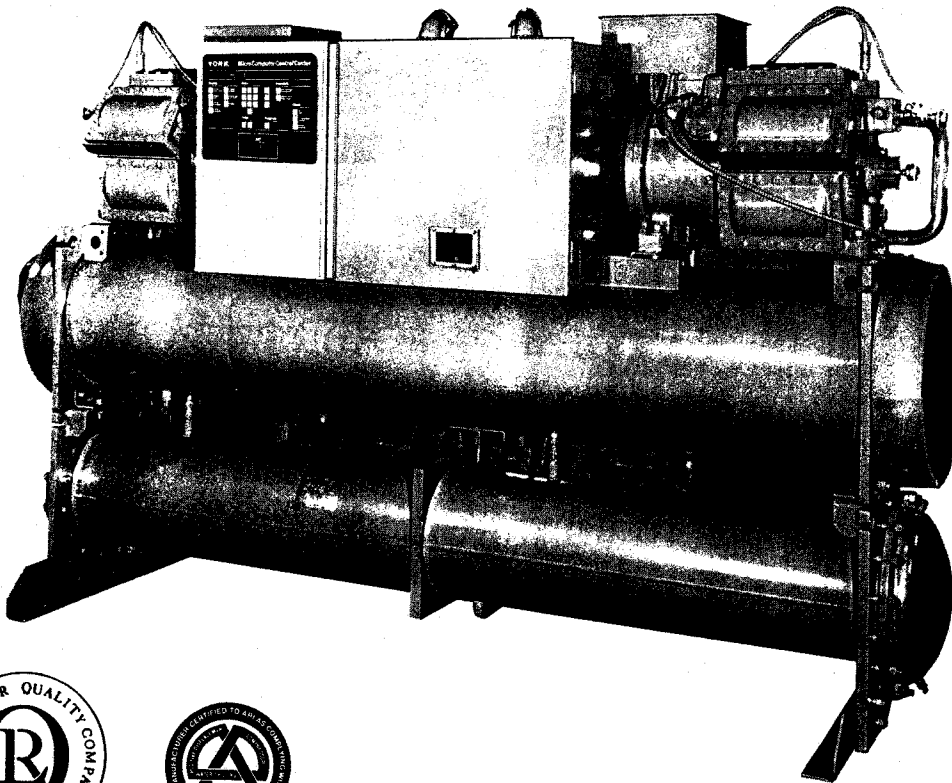

# HERMETIC ROTARY SCREW CHILLER

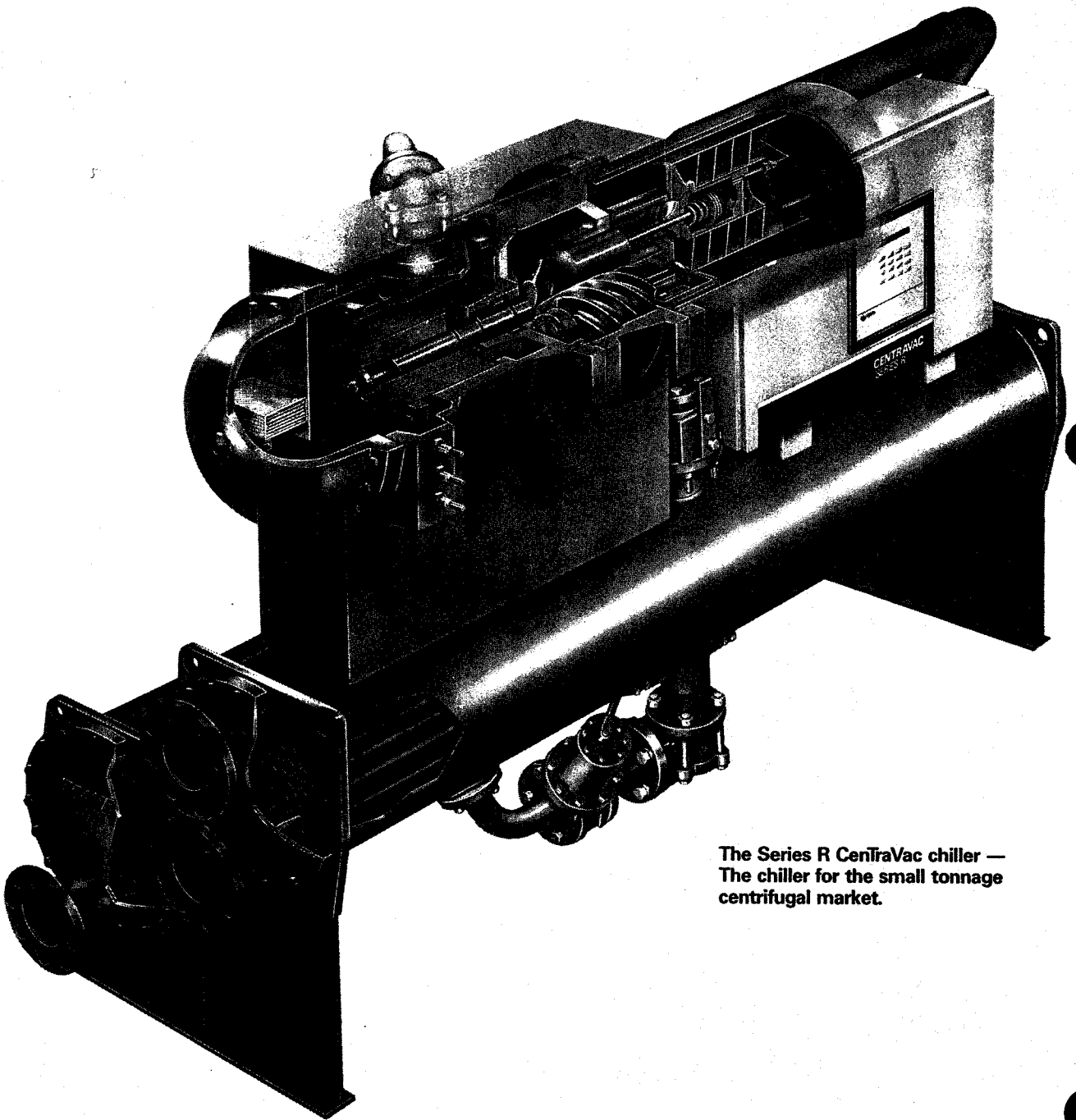

**The Series R CentraVac chiller —  
The chiller for the small tonnage  
centrifugal market.**



# Rotary Screw Liquid Chillers

OPEN DRIVE

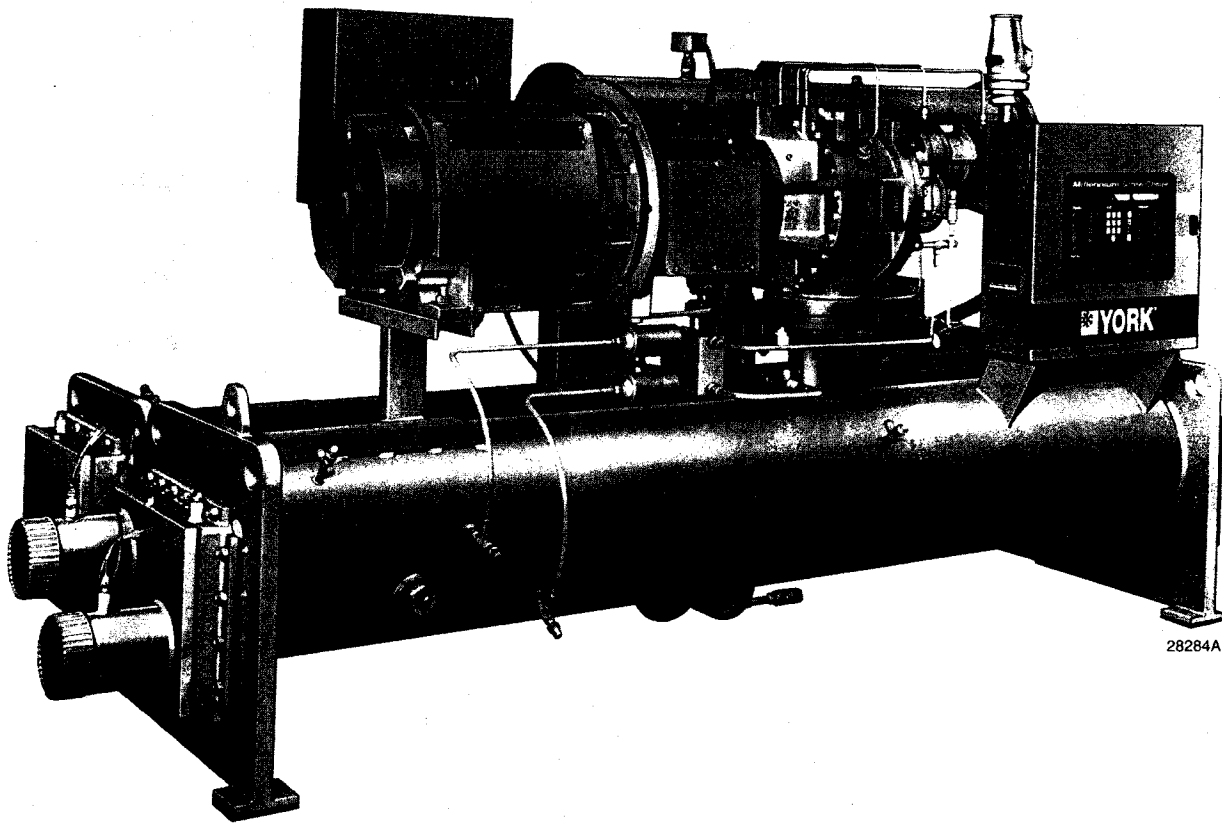

100 through 675 tons

R-22 and R-134a

# ELECTRIC DRIVE CENTRIFUGALS - HERMETIC

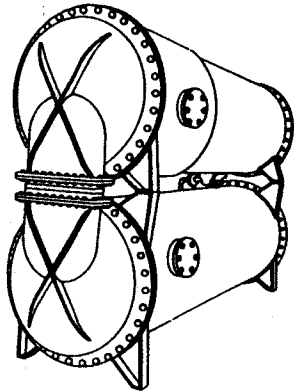

1939 — The Trane Turbovac

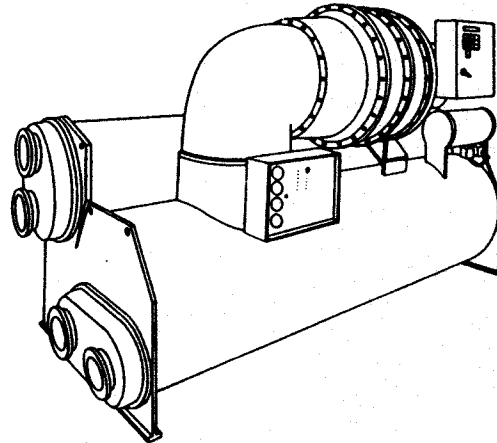

1982 — The three-stage CVHE  
CentraVac Chiller 170 TO 1300 TONS

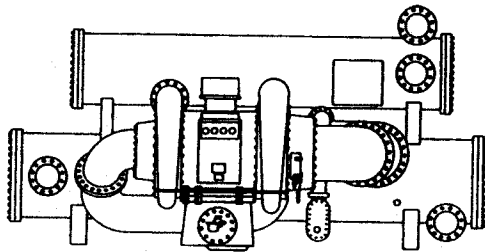

1951 — The original Trane CentraVac  
chiller

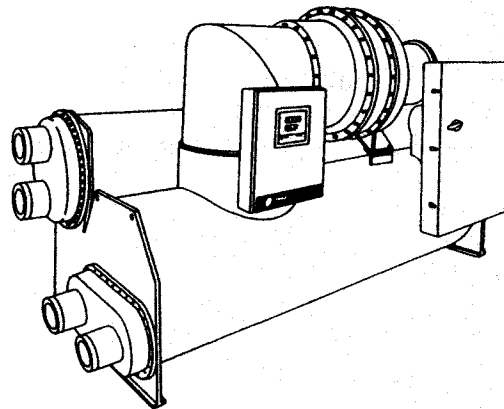

1992 — The two-stage CVHF CentraVac  
Chiller 325 TO 1500 TON

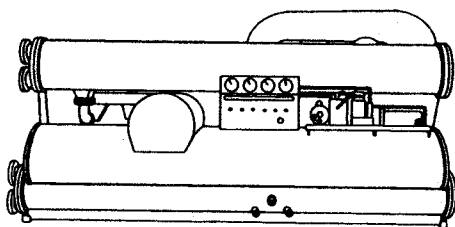

1965 — The Model PCV CentraVac  
chiller

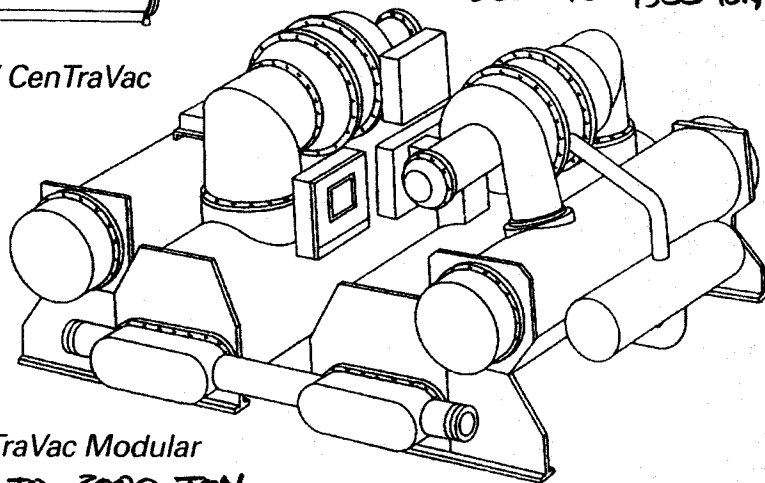

1992 — The LHCV CentraVac Modular  
Chiller system 1300 TO 3000 TON

# Centrifugal Liquid Chillers

OPEN DRIVE

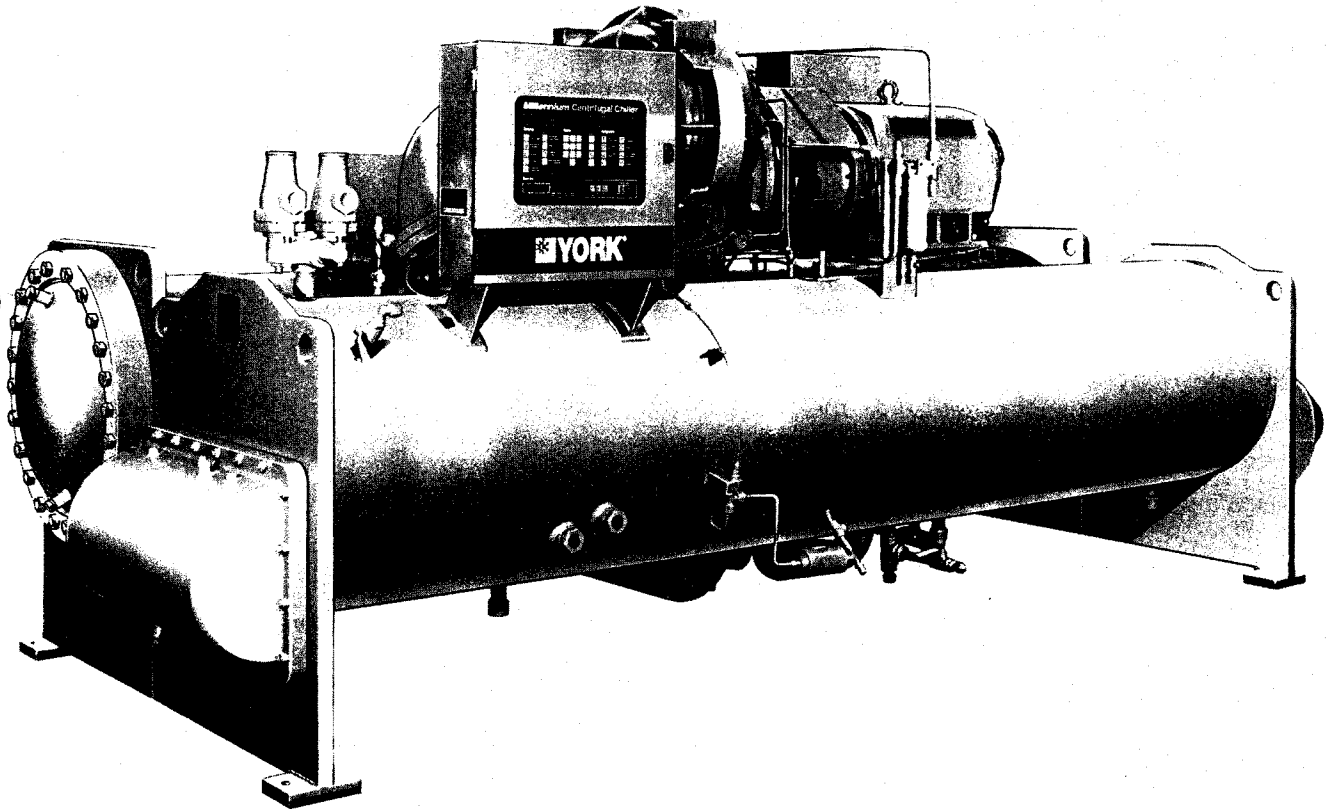

<sup>\*</sup>  
**350 THROUGH 2100 TONS**  
**Utilizing HFC-134a and HCFC-22**

<sup>\*</sup> HFC-134a 900 - 2100 TONS  
350 - 900 DESIGN LEVEL.



Rated in Accordance  
with the latest edition  
of ARI STANDARD 550

# Air Cooled Reciprocating Liquid Chillers

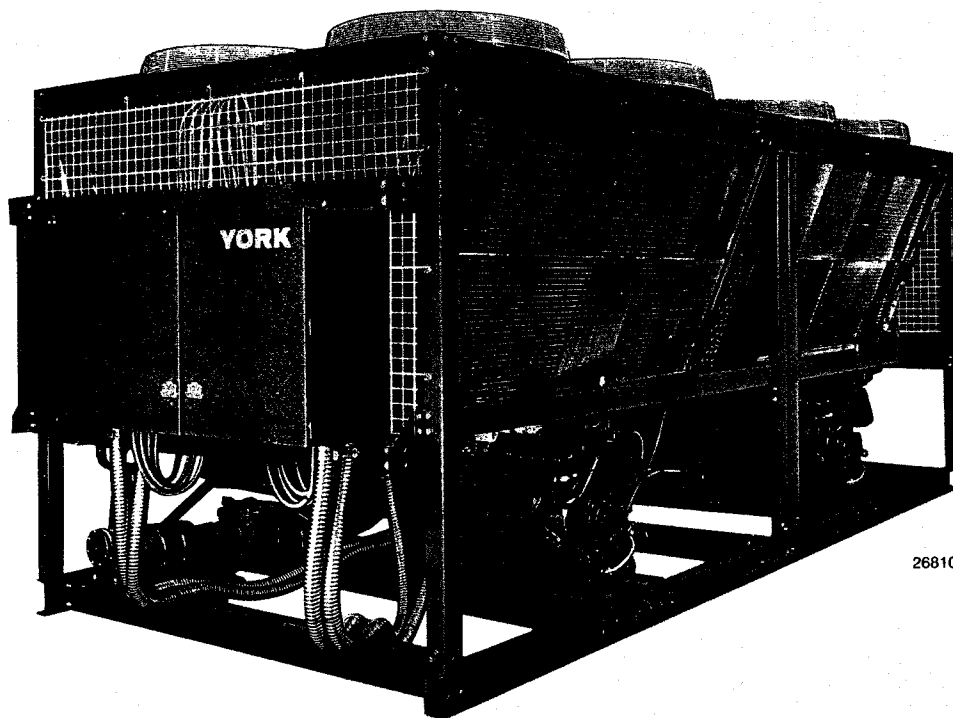

26810A



50 - 200 TONS

50 TO 230 TONS

60 HZ



C

See page 4  
for U.L. and C.U.L.  
approved models.



Metric Conversions

ROTARY SCREEN - AIR COOLED

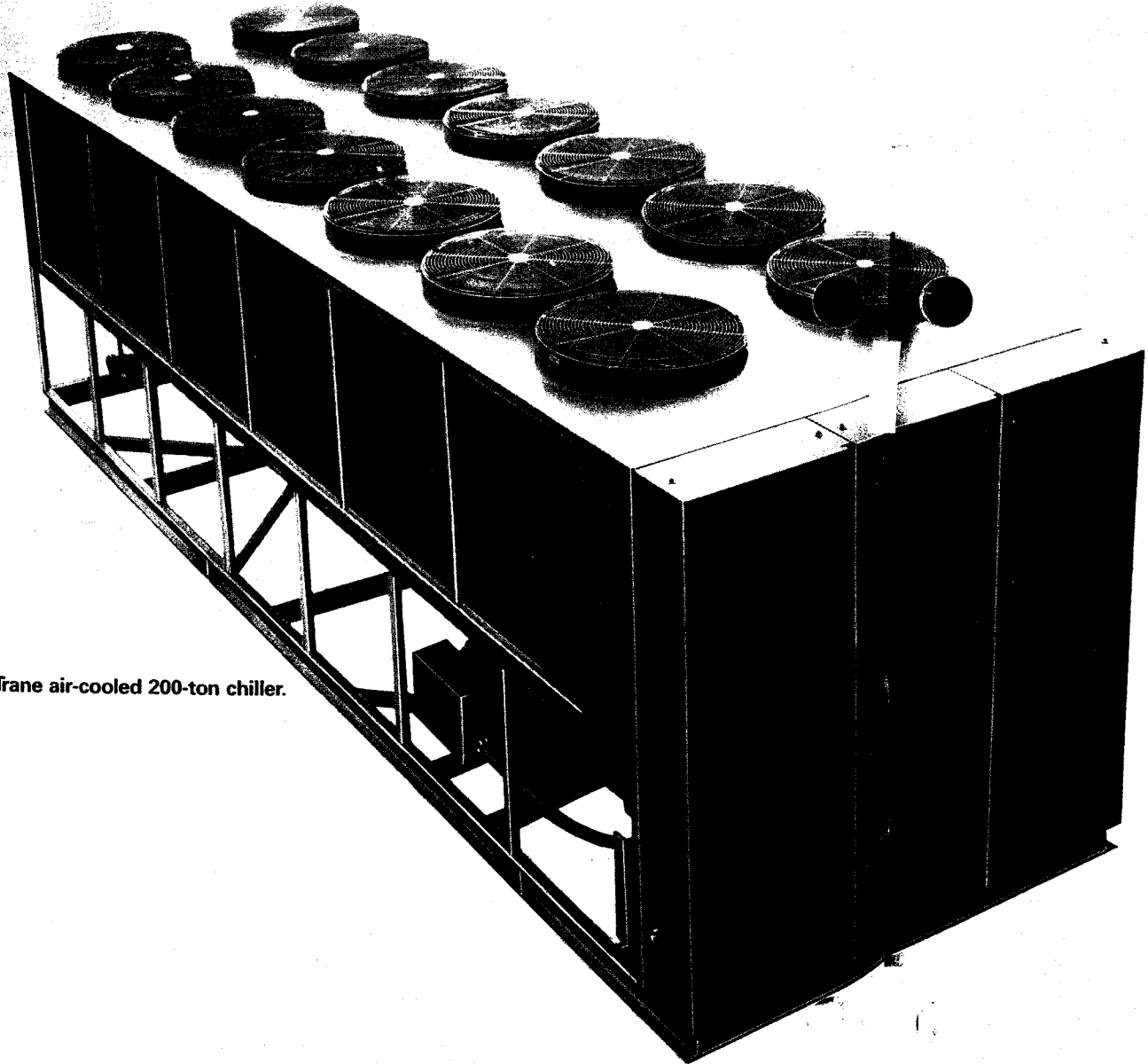

Trane air-cooled 200-ton chiller.

# **GAS-ENGINE-DRIVE CHILLERS**

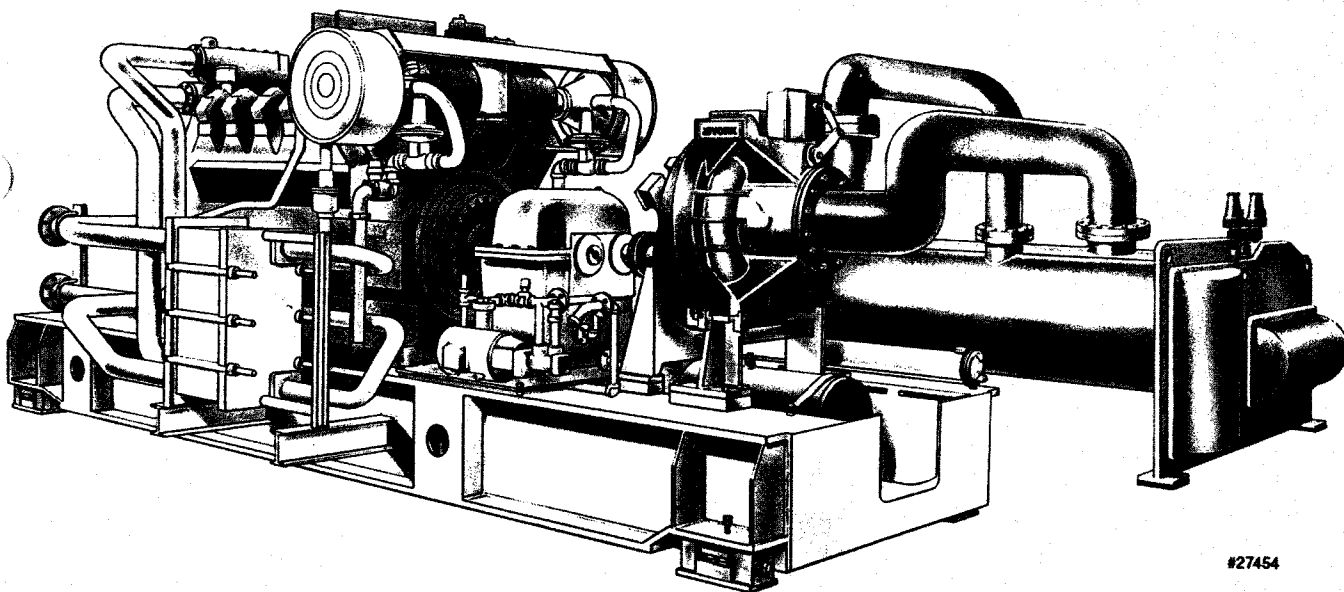

#27454

**400 Through 2100 Tons  
Utilizing HFC-134a**

# Two-Stage Steam-Fired Absorption Chiller

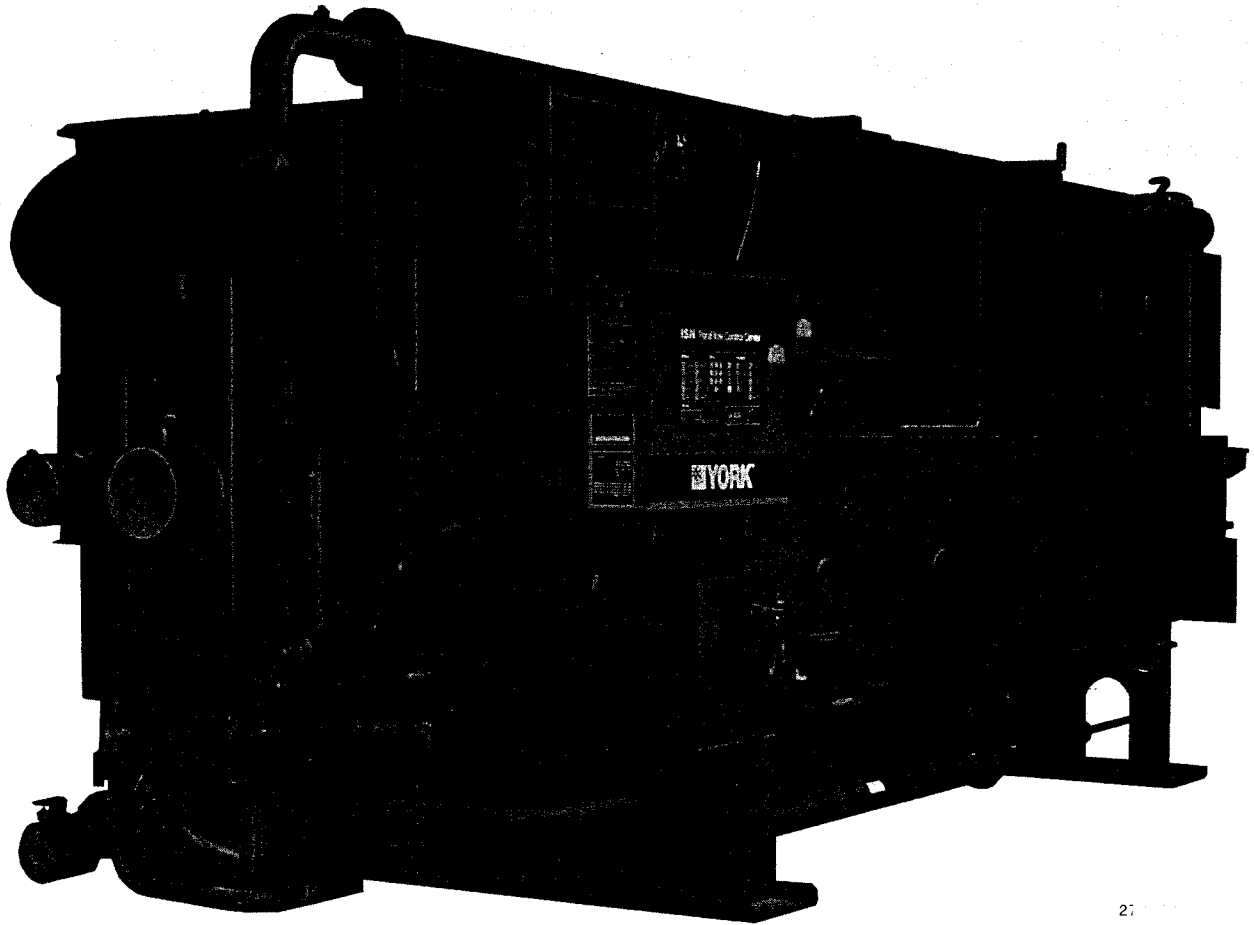

300 through 675 Tons

